

Stero Rack Conveyor DISHWASHERS TABLE LIMIT SWITCH KIT ML-138163-Z INSTALLATION INSTRUCTIONS

Table limit switch kit for Stero Rack Conveyors.



WARNING Disconnect the electrical power to the machine and follow lockout / tagout procedures.

Installation

1. Drill mounting holes in dish table using supplied template (refer to fig.1).
2. Position actuator rod and hinge assembly on the table (refer to fig. 2).
3. Mount switch assembly (refer to fig. 3) on the table using supplied 10-24 x 1/2" hex bolt and washers WS-023-03 and WL-006-06 (refer to fig. 2).
4. Mount switch assembly spring (refer to fig. 3) to actuator hinge (refer to fig. 2).
5. Mount actuator plate using supplied machine screws SC-066-06 (refer to fig.2).
6. For electrical connections refer to supplied installation drawing 01-555111.

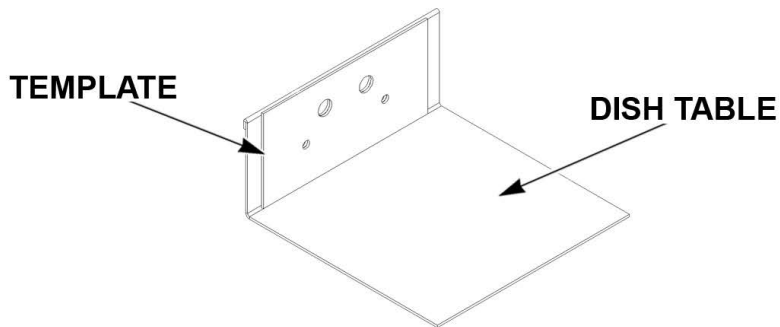

FIG. 1

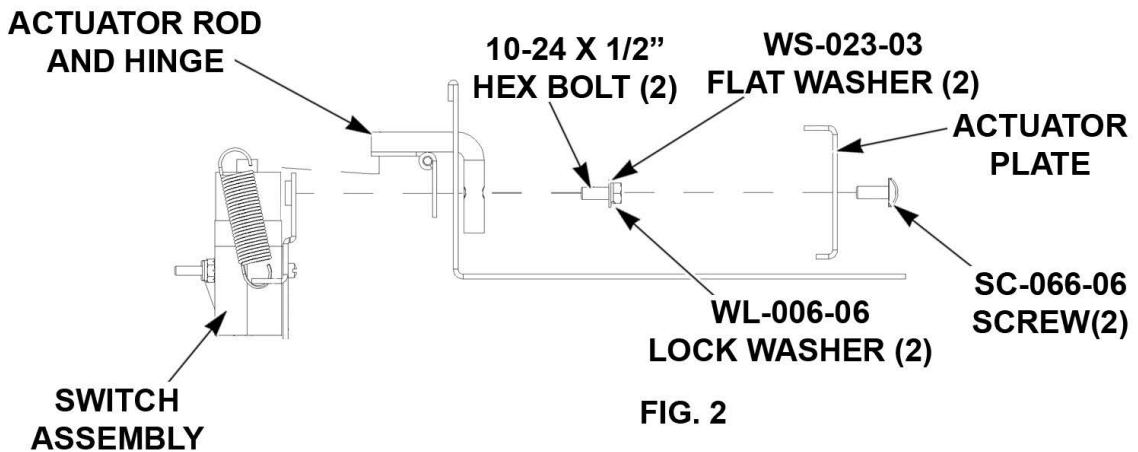

FIG. 2

FIG. 3

19806